

Measuring Volumes

Abstract

This note deals with the measuring of net volumes in connection with the positive list and energy labelling scheme for professional kitchen cabinets.

The energy consumption should be measured according to DS/EN 441-9:1994 and the net volume according to DS/EN 441-3:1994 section 3.1 and 3.2, which correspond to prEN 23953-2:2003 section 5.2.2.

Background

The energy consumption is measured in connection with energy labelling schemes for kitchen cabinets.

The energy consumption is measured according to relevant standards cf. below table.

Category	Energy consumption measured according to
Domestic refrigerators and freezers	DS/EN 153:1995 (and ISO 5155, 7371, 8187 and 8561)
Refrigeration display cabinets	DS/EN 441-9:1994 (which will be replaced by prEN 23953:2003 in the near future)
Professional kitchen cabinets	No standard deals with professional kitchen cabinets. The most obvious is to use EN 441

The energy consumption is often seen in relation to the size of the cabinet thereby accepting that large cabinets use more (absolute) energy than small cabinets.

The size of the cabinet is often related to the net volume of the cabinet, the purpose of the cabinet being to store a quantity of goods and the quantity of goods in the cabinet is limited by the net volume of the cabinet.

The size of the cabinet could also be related to other measures, e.g. the cabinet's:

- gross volume
- shelf area
- the number of sample packages in the temperature test in EN 441-5
- the maximum number of sample packages (in the net volume)
- display-area (Total Display Area, TDA) for refrigeration display cabinets
- etc.

However, the above seldom occurs.

Determination of net volume for professional refrigeration cabinets according to "the Danish system"

The net volume is measured according to DS/EN 441-3:1994 section 3.1 and 3.2, which also correspond to prEN 23953-2:2003 section 5.2.2.

Below a Danish description (translated into English) is given:

1. Definitions

Load limit

For each part of the cabinet, boundary surface consisting of one or several planes within which all test packages may be stored within the temperature limits of the actual temperature class (M1 or L1).

Load limit line

Permanently marked boundary line representing an edge of the load limit line.

Net volume

Volume within the load limit that can contain goods.

2. Preparation

The cabinet should be assembled with all components and mounted for normal use in accordance with the instructions from the producer.

When measuring the net volume all components necessary for normal use of the cabinet, including shelves, should be assembled according to intention. Measuring of net volume should be performed with the same number and placement of shelves as stated in the loading plan in connection with the temperature and energy test.

Measuring should be carried out when the equipment is not in operation, but mounted under the conditions valid for climate class 4.

3. Execution

The load limits are identified, e.g. shelf edges (front edges, rear edges, and side edges) will form a load limit.

Special attention should be given to possible air channels that are not allowed to be blocked by goods - whether the channels are open or closed.

Volumes in which it is not possible to place a cubic test package of 100x100x100 mm must not be included in the net volume.

The net volume should be determined by dividing the total net volume into suitable volume units with geometrical shapes that are easily measured (primitives).

The volume of the bottom shelf shall not be included in the net volume. The volume of all other shelves shall be included in the net volume. (This procedure is recommended in order to avoid speculation in number of shelves in connection with the tests).

The measuring of the net volume shall be documented by means of sketches showing the volume units into which the net volume is divided and their measurements. The measurements should also be documented by means of a table showing how the net volume is calculated based on the measures of the volume units.

For many appliances the net volume will be the volume of a column, limited by the upper side of the lower shelf, the edges of the shelves and the load limit in the top of the cabinet.

4. Tolerances

Measurements shall be made with measuring equipment that is within the calibration period.

The tolerance of linear dimensions is ± 3 mm. Linear dimensions must be given in millimetre.

Volume units must be given in litre with two decimals.

Net volume must be rounded off to the next full litre and must be stated in full litres.

In random control the measured net volume must not be smaller than 97% of the indicated net volume. It must be ensured that the indicated net volume is determined according to the current method.

5. Documentation

In random control the measured and the indicated net volume and their percentage distribution shall be stated in the test report.

Appendix: Different sources for this note

Determination of net volume for domestic refrigerators and freezers

In the domestic standards (ISO 5155, 7371, 8187, and 8561) the net volume (storage volume) is determined on behalf of the gross volume from which a number of contributions are removed:

$$\text{Net volume} \equiv \text{Gross volume} - \Sigma V_i$$

ΣV_i being the sum of non-applicable volume contributions.

As an example reference is made to below extract from ISO 5155.

7.2.3 Storage volume of frozen food storage cabinets and freezers

The storage volume of these appliances shall be the gross volume minus the following (for example, see figure 17):

(...)

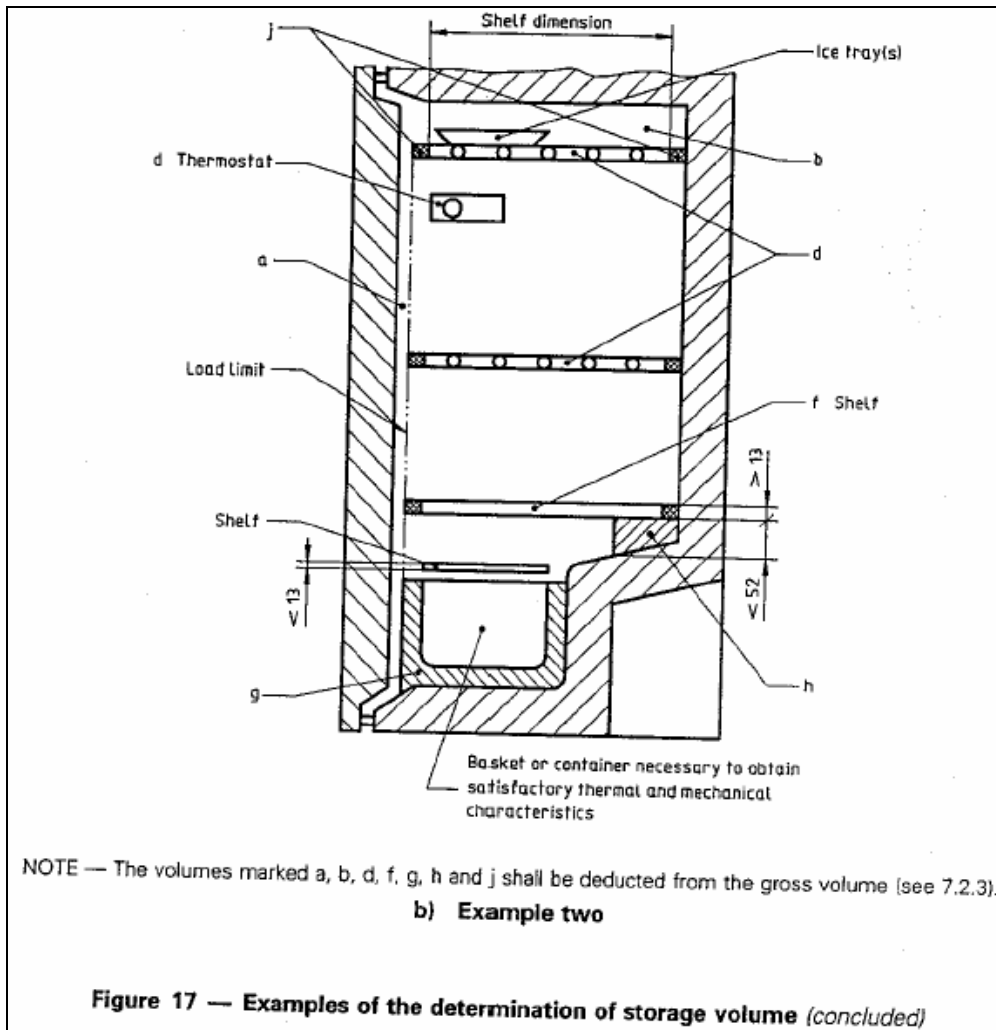

Determination of net volume for refrigeration display cabinets according to EN 441

EN 441-1:1994 (Terms and definitions) states the following:

3.6 Net volume: Volume containing food products within the load limit. Parts necessary for the proper functioning of the cabinet, including shelves used in the calculation of refrigerated shelf area, are fitted as intended and the volume representing the space occupied by these parts is deducted from the gross volume when the net volume is determined.

and EN 441-3:1994 (Linear dimensions, areas and volumes) states the following:

3.1 Physical dimensions

The manufacturer shall for each cabinet state the following nominal data according to the definitions given in EN 441-1:

(...)

e) net volume.

Measurements shall be made with the cabinet not in operation but situated in ambient conditions corresponding to the climate class (see EN 441-4) for which it is intended.

3.2 Tolerances

(...)

b) The area and volume values required in 3.1 and calculated according to the definitions given in EN 441-1 shall not be less than 97% of the stated values.

4 Test report

The test report shall clearly state:

(...)

g) the net volume for each temperature class declared.

(...)

The volumes shall be expressed in litres without decimal or cubic metres to three decimal places.

Determination of net volume for refrigeration display cabinets according to prEN 23953

In prEN 23953-1:2003 (Terms and definitions) the following is stated:

3.3.1

Refrigerated shelf area

Display area where the vertical clearance above any shelf or base deck is higher than or equal to 100 mm, measured perpendicularly above the plane of the shelf or base deck and within the bounds of any load limit.

(...)

3.3.6

Load limit

For each part of the cabinet, boundary surface consisting of a plane or several planes within which all test packages can be maintained within the limits for the M-package temperature class declared.

3.3.7

Load limit line

Boundary line permanently marked denoting the edge of the load limit surface.

3.3.8

Net volume

Volume containing foodstuffs within the load limit.

and in prEN 23953-2:2003 (Classification, requirements and test conditions):

5.2.2 Linear dimensions, areas and volumes

(...)

When measuring the net volume, parts necessary for the proper functioning of the cabinet, including shelves used in the calculation of refrigerated shelf area, are fitted as intended and the volume representing the space occupied by these parts is deducted.

(...)

Determination of net volume for professional kitchen cabinets according to “the British system”

www.eca.gov.uk states the following:

4. Internal volume

4.1 Gross internal volume

The volume within the inside walls of the cabinet without internal fittings and with the door(s) or drawers closed.

4.2 Net internal volume

The volume within the inside walls of the cabinet that remains in the loadable space (i.e. within load lines and limits) after deduction of the volume of components and air ducting and of space recognised as unusable for the practical storage of food.

5. Preparation

The cabinet shall be assembled with all its components, and set up and sited as it would be installed in service in accordance with the manufacturer's instructions.

Four shelves shall be used with the bottom shelf located in lowest position available, and the other three shelves evenly spaced between the bottom shelf and load line.

which is identical with the following from www.mtprog.com:

4. Internal volume

4.1 Gross internal volume

The volume within the inside walls of the cabinet without internal fittings and with the door/drawer(s) closed.

4.2 Net internal volume

The volume within the inside walls of the cabinet that remains in the loadable space (i.e. within load lines and limits) after deduction of the volume of components and air ducting and of space recognised as unusable for the practical storage of food.

5. Preparation

The cabinet shall be assembled with all its components, and set up and sited as it would be installed in service in accordance with the manufacturer's instructions.

Four shelves shall be used with the bottom shelf located in lowest position available, and the other three shelves evenly spaced between the bottom shelf and load line.

